

The background image shows an industrial facility with various pipes, tanks, and structural elements. A vertical split in the image separates the left side into a blue-tinted area and the right side into a yellow-tinted area. The text is overlaid on this background.

ONTEC

STEPS AHEAD

# OntecMiloX

EU Module B and -MID  
approved liquid  
loading and measurement  
system for ATEX areas

# BENEFITS - OntecMiloX

MiloX - product combination, is standardized to comply with Measuring Instrument Directive MID 2014/32/EU Module B. MiloX is totally new product system, which ensures whole new way of working to our customers. MiloX is combination of different functions that together form a system which fulfils the recommendations and requirements of OIML and WELMEC. Ontec MiloX is a measuring system complying with the European Union Measuring Instruments Directive (MID 2014/32/EU). It is MID MI-005 approved dynamic measuring system for measuring liquids other than water.



Product combination is approved and comply with the requirements of standards



Optimized installation at site, the system is ready at once



All parts of the system are approved and comply with the requirements of standards



Seamless delivery when one supplier is responsible of the project



High performance and reliability



Reduces downtime at the site during integration

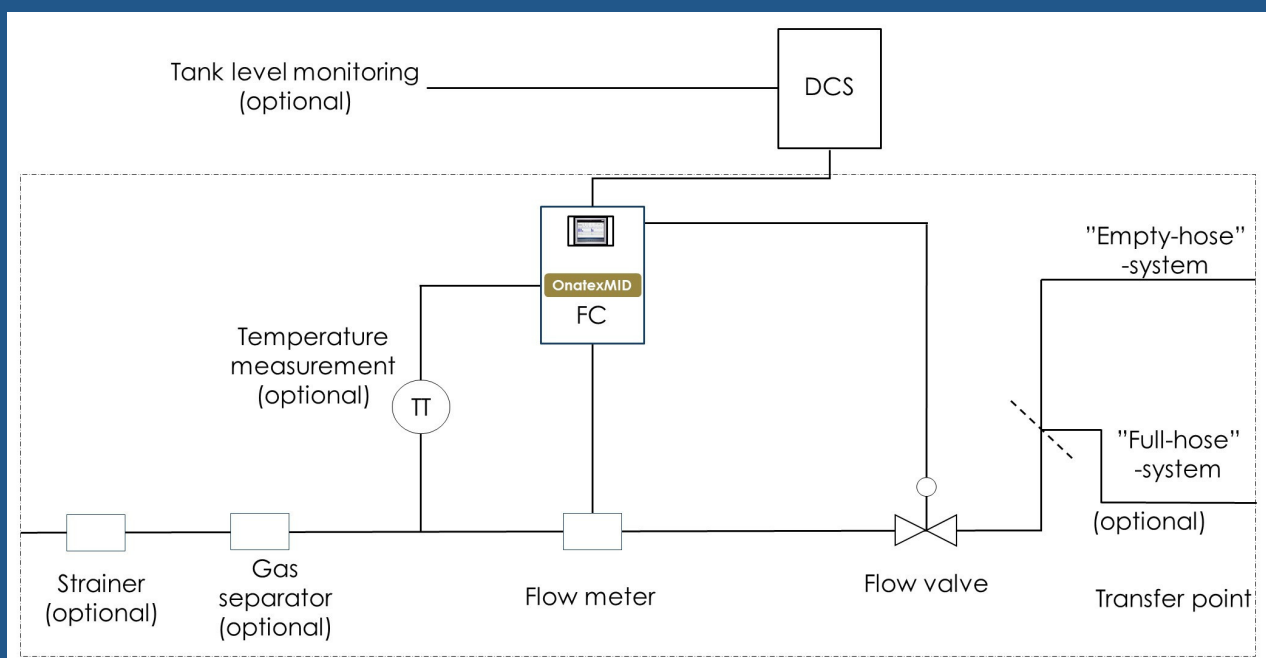

Picture. Simplified diagram of MiloX product combination

# OntecMiloX - specifications



MiloX - product combination, is standardized to comply with Measuring Instrument Directive MID 2014/32/EU Module B



Ontec MiloX is a measuring system complying with the European Union Measuring Instruments Directive (MID 2014/32/EU) for ATEX - areas



MiloX is combination of different functions that together form a system which fulfils the recommendations and requirements of OIML R117-1 and WELMEC 7.2 ja WELMEC 8.8



Approved for fiscal billing purposes (fuel taxation, custody transfer)



Audit trail, full record of events, ensures your possibility to track back all data history of each transaction



OntecMiloEX- touch screen and software for ATEX - areas



Recipe systems for each customer products and additives



Customisation to meet the needs of each terminal customer (order protocols, consignment notes, numerisation of compartments etc.)



Real-time inventory management

# MILOX EQUIPMENT STANDARDS AND CERTIFICATES; PIPES AND STEEL STRUCTURES

## **ISO 9001**

certified quality management system

## **EN 1090**

exc2 level CE-marking permission of steel structures

## **ISO 3834-2**

certified welding

**Neste H-module  
qualified operator**

## **A2 module marking permission**

category II pressure equipment: design, manufacturing, installation,  
modification and repair

# ONTEC OY QUALITY MANAGEMENT SYSTEMS AND CERTIFICATIONS

High quality is possible only when each employee is committed to it. We develop the expertise of our employees constantly by training them in-house and by outside experts. Everyone at Ontec is keen on developing our working methods. Strengths of Ontec Oy are: understanding the big picture of the industry, knowing our clients and their production processes, clients receive full solutions to their problems, agility and short response times.

## ISO 9001

Quality Management System since 2012

## ATEX

QMS for Potentially explosive atmospheres (directive 2014/34/EU)

## KATAKRI

Ontec Oy's premises, operating methods, and electronic data processing equipment are Katakri 2020 qualified

## KNOWN SUPPLIER

Known Supplier of Airport Supplies



## T10

Our health and safety processes are T10 audited

# CONTACT US

## ONTEC OY

Sutelantie 277

48400 KOTKA

## SALES & MARKETING

Kare Kupiainen

+358 440 668 321

kare.kupiainen@ontec.fi

## PROJECTS

Esa Käyhty

+358 440 668 322

esa.kayhty@ontec.fi

## MARKETING & QUALITY

Tanja Karpale

+358 451 177 701

tanja.karpale@ontec.fi

ONTEC.FI 

